

## Mounting Hardware for Combination Units

To convert individual Filter, Regulator and Lubricators into combination units. Seals included.

FRL Series	Spacer with L Bracket	Spacer with T Bracket	Dim.	MMH-Y10L	MMH-Y20L	MMH-Y30L	MMH-Y40L	MMH-Y50L	MMH-Y60L
				MMH-Y10T	MMH-Y20T	MMH-Y30T	MMH-Y40T	MMH-Y50T	MMH-Y60T
FRL-1	<a href="#">MMH-Y10L</a>	<a href="#">MMH-Y10T</a>	H1	1.06	1.30	1.77	1.97	1.97	2.48
FRL-2	<a href="#">MMH-Y20L</a>	<a href="#">MMH-Y20T</a>	H2	2.13	2.60	3.54	3.94	3.94	4.96
FRL-3	<a href="#">MMH-Y30L</a>	<a href="#">MMH-Y30T</a>	L	0.47	0.59	0.63	0.87	0.87	0.91
FRL-4W/4Z	<a href="#">MMH-Y40L</a>	<a href="#">MMH-Y40T</a>	LS	0.18	0.22	0.28	0.35	0.35	0.47
FRL-4A	<a href="#">MMH-Y50L</a>	<a href="#">MMH-Y50T</a>	HM	0.12	0.12	0.16	0.16	0.16	0.16
FRL-5	<a href="#">MMH-Y60L</a>	<a href="#">MMH-Y60T</a>	TS	0.20	0.20	0.28	0.28	0.28	0.41
			RM	0.09	0.11	0.14	0.18	0.18	0.24
			HS1	0.79	0.94	1.38	1.57	1.57	1.97
			HS2	1.57	1.89	2.76	3.15	3.15	3.94

## Spacers

To convert individual Filter, Regulator and Lubricators into combination units without mounting brackets. Seals included.

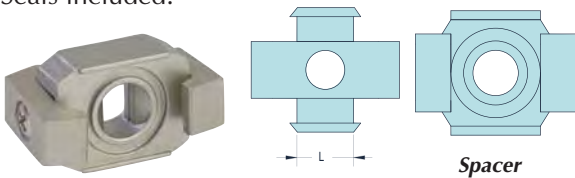

Series	Part No.	"L" Dimension
FRL-1	<a href="#">MMH-Y10</a>	0.32
FRL-2	<a href="#">MMH-Y20</a>	0.41
FRL-3	<a href="#">MMH-Y30</a>	0.44
FRL-4W/4Z	<a href="#">MMH-Y40</a>	0.55
FRL-4A	<a href="#">MMH-Y50</a>	0.57
FRL-5	<a href="#">MMH-Y60</a>	0.61

## Spacers with Auxiliary Port

Provides parallel port between components.



**MMH-Y21-N01**

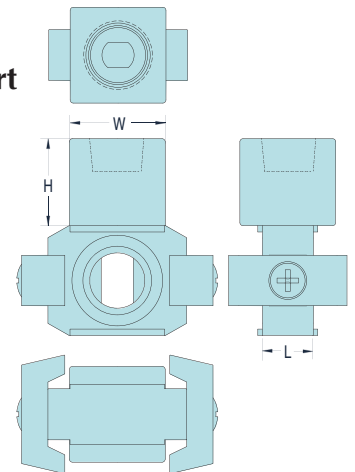

FRL Series	Spacer with Port	Spacer with L Bracket & Port	Spacer with T Bracket & Port	Dimension		
				L	H	W
FRL-2	<a href="#">MMH-Y21-N01 (1/8")</a>	<a href="#">MMH-Y21L-N01 (1/8")</a>	<a href="#">MMH-Y21T-N01 (1/8")</a>	0.41	0.69	0.76
	<a href="#">MMH-Y21-N02 (1/4")</a>	<a href="#">MMH-Y21L-N02 (1/4")</a>	<a href="#">MMH-Y21T-N02 (1/4")</a>	0.41	0.69	0.76
FRL-3	<a href="#">MMH-Y31-N01 (1/8")</a>	<a href="#">MMH-Y31L-N01 (1/8")</a>	<a href="#">MMH-Y31T-N01 (1/8")</a>	0.44	0.64	0.75
	<a href="#">MMH-Y31-N02 (1/4")</a>	<a href="#">MMH-Y31L-N02 (1/4")</a>	<a href="#">MMH-Y31T-N02 (1/4")</a>	0.44	0.64	0.75
FRL-4W/4Z	<a href="#">MMH-Y41-N02 (1/4")</a>	<a href="#">MMH-Y41L-N02 (1/4")</a>	<a href="#">MMH-Y41T-N02 (1/4")</a>	0.55	0.71	0.94
	<a href="#">MMH-Y41-N03 (3/8")</a>	<a href="#">MMH-Y41L-N03 (3/8")</a>	<a href="#">MMH-Y41T-N03 (3/8")</a>	0.55	0.71	0.94
FRL-5	<a href="#">MMH-Y61-N03 (3/8")</a>	<a href="#">MMH-Y61L-N03 (3/8")</a>	<a href="#">MMH-Y61T-N03 (3/8")</a>	0.61	0.79	1.18
	<a href="#">MMH-Y61-N04 (1/2")</a>	<a href="#">MMH-Y61L-N04 (1/2")</a>	<a href="#">MMH-Y61T-N04 (1/2")</a>	0.61	0.79	1.18